

CONTROLLER CABINET

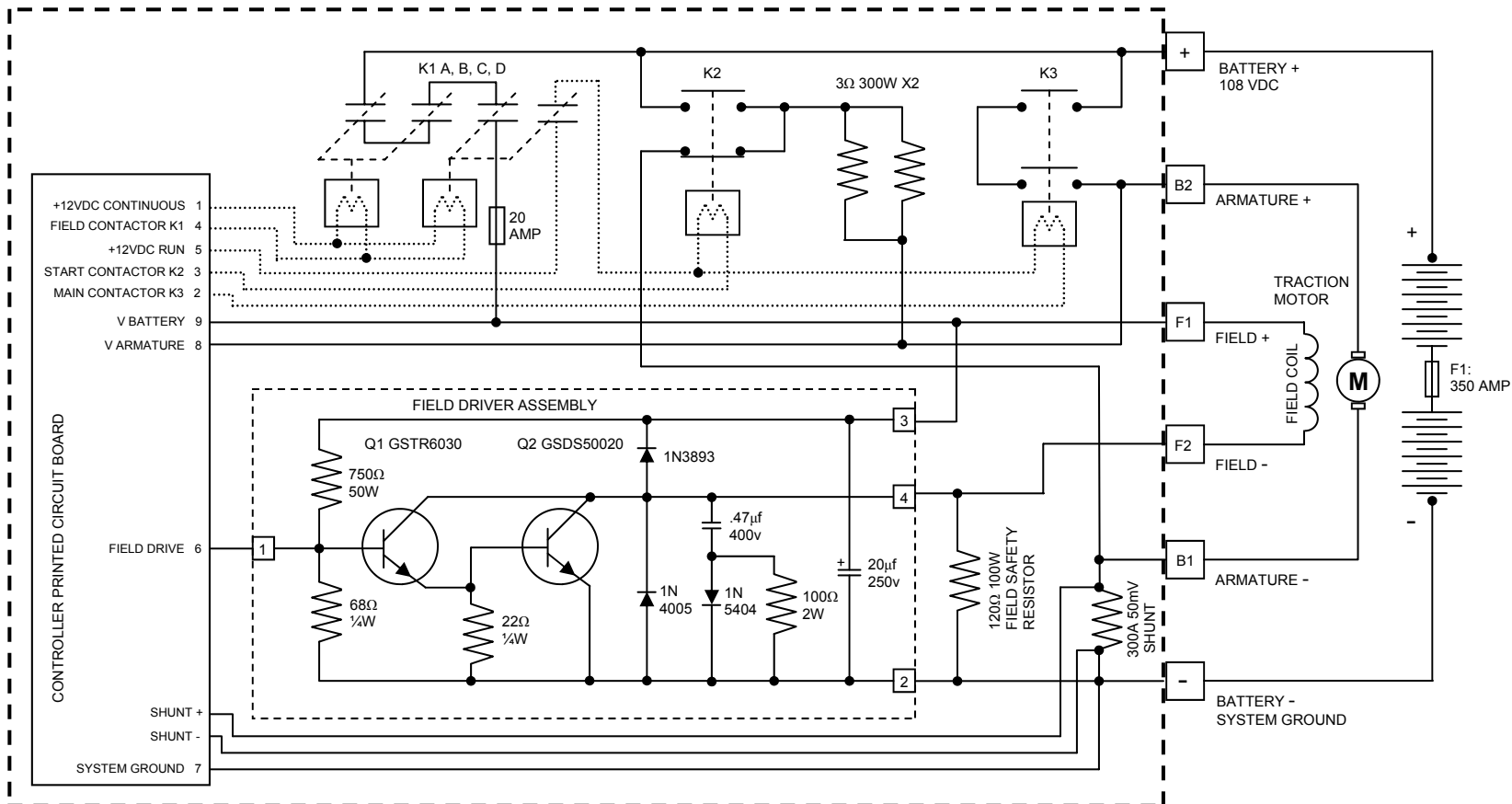

NOTES:

- 1) ALL RELAY AND CONTACTOR COIL WIRING DRAWN WITH DOTTED LINES FOR CLARITY OF REMAINDER OF DIAGRAM
- 2) WIRING SHOWN RELATES TO MOTOR FIELD AND ARMATURE POWER CIRCUITRY ONLY - SEE OTHER DIAGRAMS FOR ADDITIONAL WIRING

REVISIONS:

- 1) Feb 08, 2007
- 2) Feb 09, 2007
- 3) Feb 10, 2007
- 4) Jun 01, 2007



1981 SCT RABBIT CONVERSION
MAIN CONTROLLER AND FIELD SCHEMATIC DIAGRAM
Meticulously created/redrawn February 2007 by:
Mr. Sharkey
<http://www.mrsharkey.com/SCT>